

Greed doesn't grow on trees: the indirect association between proenvironmental behaviour and materialism through adolescents' psychological entitlement

Meiting Liu and Aki Koivula

Abstract

Purpose – This study aims to explore the potential that acting proenvironmentally protects adolescents from developing materialistic value.

Design/methodology/approach – Convenience sampling was adopted to collect data from two randomly selected secondary schools in central China. A total of 784 participants were included in the survey.

Findings – The mediation analysis revealed that adolescent proenvironmental behaviour was negatively associated with materialism. The results of the moderated mediation model showed that psychological entitlement mediates the association between adolescent proenvironmental behaviour and materialism, and that family socioeconomic status acts as a moderator in the association between proenvironmental behaviour and psychological entitlement.

Practical implications – The current results advise educational practitioners on alleviating adolescent materialism. Policy makers and schools can add more environmental practice to the curriculum and extracurricular activities. Moreover, identifying the personal benefits of proenvironmental behaviour can motivate young people to act proenvironmentally, which not only factually reduces over-consumption but also attracts more attention from young people to the environment.

Originality/value – Previous studies rarely explored the individual belief or perception accounting for the negative association between proenvironmental behaviour and materialism. Therefore, the authors adopt psychological entitlement, a belief reflecting the dark side of individual perception, to explain why proenvironmental behaviour reduces materialism.

Keywords Adolescence, Materialism, Proenvironmental behaviour, Psychological entitlement, Family socioeconomic status

Paper type Research paper

Meiting Liu and Aki Koivula both are based at the Faculty of Social Sciences, University of Turku, Turku, Finland.

Received 11 September 2021
Revised 20 December 2021
8 March 2022
17 May 2022
Accepted 9 July 2022

© Meiting Liu and Aki Koivula. Published by Emerald Publishing Limited. This article is published under the Creative Commons Attribution (CC BY 4.0) licence. Anyone may reproduce, distribute, translate and create derivative works of this article (for both commercial and non-commercial purposes), subject to full attribution to the original publication and authors. The full terms of this licence may be seen at <http://creativecommons.org/licenses/by/4.0/legalcode>

1. Introduction

A majority of studies have paid attention to factors and strategies that drive people to live and consume products environmentally friendly (Goldstein *et al.*, 2008; Gleim *et al.*, 2013; Gupta *et al.*, 2022). Scholars and policy makers have also convinced people that going green will guide us all in tandem to a clean, wholesome and sustainable planet (Griskevicius *et al.*, 2012; York *et al.*, 2018). However, within a large body of green-related research, there is a relative lack of academic interest in topics regarding how one can personally benefit from practising proenvironmental behaviour. Only until more recently, studies have revealed that consumers can gain personal benefits from proenvironmental behaviour (Tezer and Bodur, 2020; Kasser, 2017; Kang *et al.*, 2021).

Adolescence has been regarded as a key period of developing prosocial values and tendencies, which will be constantly relevant for adulthood (Eisenberg *et al.*, 2002). However, one of the most poignant and surprising contemporary observations about adolescent life is the increasing trend where adolescents mindlessly justify materialism (Chaplin and John, 2007; de Rezende Pinto *et al.*, 2017), a value that features an emphasis on acquiring money and items, the mere possession of material goods and an insurance for happiness if one eventually acquires those goods (Belk, 1985; Richins and Dawson, 1992). Shrewd marketers have peddled consumerism through social media by encouraging and building a dream for young people that money and materials are the shortcut, if not the only way, to happiness (Lewallen *et al.*, 2016).

Research has demonstrated that materialism is associated with negative outcomes in adolescence – e.g. decreased school performance (Goldberg *et al.*, 2003), mental issues among 18-year-olds (Kasser and Ryan, 1993), social comparison with media figures (Chan and Prendergast, 2007), strong interest in fashion and clothing (Kamal *et al.*, 2013), high intention to get plastic surgery (Henderson-King and Brooks, 2009), and low life satisfaction (Ku, 2015). In terms of prosocial attitudes, adolescents who hold materialistic value are less likely than non-materialists to help others (Briggs *et al.*, 2007), advocate for egalitarian (Flanagan *et al.*, 2005) and have less ecologically responsible behaviour (Brown and Kasser, 2005).

Moreover, exposure to material parenting in adolescence increases the likelihood of developing adulthood materialism (Richins and Chaplin, 2015), which subsequently engenders risky health behaviours (e.g. tobacco, alcohol or drugs) and compulsive buying (Ding *et al.*, 2019a; Dittmar *et al.*, 2014), and develops negative self-evaluation (Dittmar *et al.*, 2014), problematic interpersonal relationships (Norris *et al.*, 2012), recurrent loneliness (Pieters, 2013) and dark personality traits (Kasser and Ryan, 1993; McHoskey, 1999). In the Chinese context, exploring adolescent materialism is particularly important because development of the Chinese economy brings about an increasing desire for material hedonism among young people in modern Chinese society (Chan *et al.*, 2006; Chan and Prendergast, 2008; Durvasula and Lysonski, 2010; Gu and Hung, 2009; Podoshen *et al.*, 2011).

Kasser (2016) proposed three approaches to reducing materialism: activating self-transcendent values, removing materialistic cues in the social environment and improving one's sense of security. In principle to the approaches, previous studies have reported successful interventions (Stillman *et al.*, 2012; Brown *et al.*, 2009; Buijzen, 2007; Chaplin and John, 2007; Clark *et al.*, 2011; Lasaleta *et al.*, 2014), while few studies have explored whether proenvironmental behaviour can decrease materialism. Given that green consumption provides a sense of self-worth among consumers (Tezer and Bodur, 2020), we believe that proenvironmental behaviour may activate self-transcendent values, which is a possible way to reduce materialism (Kasser, 2016). Moreover, materialism-related values lie opposite to proenvironmental value on the circular model of the value system (Maio *et al.*, 2009; Schwartz *et al.*, 2012), which suggests that increasing one means decreasing the other. Therefore, we assume that acting proenvironmentally may protect adolescents from developing materialistic value.

Although previous studies have copiously revealed the link between proenvironmental behaviour and materialism (Kilbourne and Pickett, 2008; Bergman *et al.*, 2014; Alzubaidi *et al.*, 2021; for negative association, Helm *et al.*, 2019; for positive association, Evers *et al.*, 2018), the influential mechanism and demographical difference have been inadequately explored. Extant literature has indicated that environmental beliefs (Kilbourne and Pickett, 2008), proenvironmental attitudes (Gu *et al.*, 2020) and the social approval and behavioural control of green behaviour (Sreen *et al.*, 2020) act as the mediators between proenvironmental behaviour and materialism. However, these studies do not specify why people who take actions that benefit the environment can affect their immoderate search for

materialist goals. Drawing from [Bergman et al.'s \(2014\)](#) study showing that materialism explains why narcissist business students have lower levels of environmental ethics than their non-narcissist counterparts, we assume that dark beliefs may serve to interpret the negative association between proenvironmental behaviour and materialism.

In addition, from the late 20th to the early 21st century, American college students have become increasingly psychologically entitled (ego inflated) over time ([Twenge and Foster, 2010](#)). Although psychological entitlement has been consistently identified as the problem of the privileged in the western context ([Kraus et al., 2012](#)), some researchers have found that Chinese college students from a lower social class exhibit psychological entitlement when they attribute their economic disadvantage to external factors and perceive a sense of relative deprivation ([Ding et al., 2019b](#)). Accordingly, we speculate that psychological entitlement, a sub-dimension of narcissism, might be associated with proenvironmental behaviour and materialism. Therefore, we aim to examine the influential mechanism by testing psychological entitlement as a mediator in the association between proenvironmental behaviour and materialism. Furthermore, given that materialism is closely linked to money and material acquisition, we attempt to explore how adolescent family socioeconomic status moderates this hypothetical model.

1.1 Proenvironmental behaviour and materialism

As proenvironmental value and behaviour are significantly associated ([Hurst et al., 2013](#)), people who engage in proenvironmental behaviour are likely to have proenvironmental value. According to the theory of basic individual values, proenvironmental value falls within the self-transcendence dimension and the universalism–nature sub-dimension of the circular value spectrum ([Schwartz et al., 2012](#)). That is, self-interest is dwarfed in proenvironmental behaviour and inflated in materialism. People who practise proenvironmental behaviour have less motivation for boosting self-interest than improving the welfare of the entire population or nature ([Schwartz et al., 2012](#)). By contrast, materialism highlights the tendencies that one fixes on personal goals directed by hedonic or instrumental motives ([Richins and Dawson, 1992](#); [Shrum et al., 2013](#)) or social fantasies ([Solomon, 1983](#)). These tendencies are in accordance with self-enhancement goals, which stand on the very opposite of self-transcendence, where proenvironmental value is located, in the circular values model ([Schwartz et al., 2012](#); [Burroughs and Rindfleisch, 2002](#)). Furthermore, we can draw from the social learning theory ([Bandura, 1971](#)) and the social cognitive theory ([Bandura, 2018](#)) to illustrate how behaviour shapes value. As shown in the flow diagram of social learning ([Bandura, 1971](#)), the core practice for individuals to internalise a moral thought is to form a symbolic conclusion according to the feedback of their multiple behavioural trials. This is a process where behavioural factors contribute to the construction of personal values or moral thoughts. [Bandura's \(2014\)](#) emphasis of “learn by modelling” has a subtext of “learn by doing”. In accordance with the interactionist perspective of social learning ([Bandura, 2014](#); [Bandura, 2018](#)), repeated proenvironmental behaviour provides adolescents with social worth and warm-glow feelings ([Tezer and Bodur, 2020](#)), which are positive feedback that restrains self-centred attitudes and values, e.g. materialism. Thereby, we propose:

H1. Proenvironmental behaviour will have a negatively significant impact on materialism.

1.2 Psychological entitlement as a mediator

Psychological entitlement is a self-centred belief where one experiences exaggerated deservingness, distinctiveness and expectations ([Grubbs and Exline, 2016](#)). Psychologically entitled individuals usually consider themselves to have more privilege than other people in various aspects of social life ([Campbell et al., 2004](#); [Barton and Hirsch, 2016](#); [Boyd and Helms, 2005](#)). Feeling entitled is negatively associated with myriads of negative outcomes that decrease well-being ([Grubbs and Exline, 2016](#)).

First, proenvironmental behaviour has a negative impact on psychological entitlement. Drawing on the circular model of basic individual values (Schwartz *et al.*, 2012), adolescents who practise proenvironmental behaviour are likely to appreciate self-transcendent values that counter to the self-enhancement values where people of high psychological entitlement usually hold (Schwartz *et al.*, 2012). In a previous study, psychological entitlement was found to be negatively associated with environmental ethics among business students (Bergman *et al.*, 2014), which substantiated the potential negative impact of proenvironmental behaviour on psychological entitlement.

Second, psychological entitlement has a positive impact on materialism. Adolescents who are less psychologically entitled tend to have more self-transcendent values and less likely to value self-interests than those who are more psychologically entitled (Schwartz *et al.*, 2012). As pursuing self-interests is a dominant feature of materialism, we believe that less psychological entitlement can lead to less materialism. In addition, given that psychologically entitled adolescents usually consider themselves to have more privilege than other people (Campbell *et al.*, 2004), it is likely that this sense of privilege blinds adolescents so that they see the world only in terms of their hedonic or instrumental goals and realise the goals by pursuing material goods. Moreover, there is empirical evidence in previous literature supporting the given relationship (Lee *et al.*, 2022; Oprea and Kühne, 2016).

Third, psychological entitlement serves as a mediator to the relationship between proenvironmental behaviour and materialism. The associations between proenvironmental behaviour, psychological entitlement and materialism can be explained through how important people evaluate the self in comparison with the larger social domains – e.g. the natural environment. Thus, we propose:

H2. Psychological entitlement will significantly mediate the causal relationship between proenvironmental behaviour and materialism.

1.3 Family socioeconomic status as a moderator

People from lower class are more likely to have more context-dependent cognitive styles through which they are more concerned about people around them rather than their own behaviour (Kraus *et al.*, 2012). Therefore, this behavioural tendency may weaken the association between proenvironmental behaviour and psychological entitlement. Moreover, adolescents from lower class may experience more social injustice than their higher class peers, and they will feel that they deserve better treatment than what they really experience. Therefore, their psychological entitlement may maintain a high level so that other factors have little effect on it. A recent study revealed that lower classed college students in China feel psychologically entitled when they attribute the rich–poor gap to external factors and feel a sense of relative deprivation (Ding *et al.*, 2019b).

Moreover, some scholars have distinguished between “vulnerable-based” and “grandiose-based” forms of psychological entitlement (Hart *et al.*, 2019). Research has revealed that people who are treated unjustly in adverse childhood may be more psychologically entitled because their vulnerability triggers demand for special consideration (Bishop and Lane, 2000). Therefore, factors that would have decreased psychological entitlement (proenvironmental behaviour) may be invalidated due to the vulnerable social conditions confronted by lower classed adolescents. Thus, we propose:

H3. Family socioeconomic status moderates the causal relationship between proenvironmental behaviour and psychological entitlement.

2. Data and methods

2.1 Participants

We adopted convenience sampling to collect data from two randomly selected secondary schools in central China. The purpose of the current study is to explore the potential that

acting proenvironmentally protects Chinese adolescents from developing materialistic value. Given that the ages of secondary school students meet the general criteria of the adolescence stage (Kim and Kim, 2009), we consider it appropriate to recruit adolescents from secondary schools in central China by means of convenience sampling.

However, convenience sampling has several limitations. For example, the research results may not be generalised to a larger population because we merely examined students from two schools in a particular district (Etikan *et al.*, 2016), particularly in China where the economic level in the south-eastern area is higher than other districts. In addition, the homogeneity may inflate the research validity because students tend to have homogeneous demographics such as age and education (Peterson and Merunka, 2014). Still, we assume that the sample is of certain representativeness because most adolescents in China are in school at this stage of life due to the nine- or 12-year compulsory education programmes launched by the government.

After deleting missing data and wrongly written answers, we included a total of 784 participants in the study. A total of 379 (48%) girls and 405 (52%) boys made up the sample. Of the participants, 59% are from the seventh grade, 16% are from the eighth grade and 25% are from the ninth grade. Their age ranges from 12 to 17 years old ($M_{\text{age}} = 13.73$, $SD_{\text{age}} = 1.06$). Merely 10% of the participants are the only child in their family.

Permissions to conduct this survey were sought from the Ethics Committee for Scientific Research of our institution, the adolescent students and the adolescents' parents.

Prior to the formal survey, students were informed about the entire procedure, the scientific and confidential use of their responses, and their right to quit at any time. The formal questionnaires covered participants' demographics, family wealth, proenvironmental behaviour, psychological entitlement and adolescent materialism. Lastly, the participants were given a few minutes to confirm the completeness of their answers.

2.2 Measures

2.2.1 Proenvironmental behaviour. We used an adapted version of proenvironmental behaviour assessment based on Krettenauer (2017) and a localised research with a Chinese adolescent sample (Wang *et al.*, 2019). The items are "I turn off TV and computer screens when they are not in use", "I conserve energy and water by taking shorter showers", "I collect and recycle used papers and plastic containers", "I properly treat the dead batteries to avoid polluting the environment", "I reuse plastic bags" and "I prefer buying products made from recyclables (e.g. notebooks made of used papers)". For each item, participants were asked to rate how often they engaged in the behaviour in the last year (from 0 = *never do this* to 5 = *always do this*).

2.2.2 Psychological entitlement. Participants filled in a Chinese version of the PE scale (Ding *et al.*, 2019b; Campbell *et al.*, 2004). The PE scale consists of nine items that describe an individual sense of entitlement. Examples of items are "I honestly feel I'm just more deserving than others", "Great things should come to me", "If I were on the Titanic, I would deserve to be on the *first* lifeboat", "I demand the best because I'm worth it" and "People like me deserve an extra break now and then". Participants' answers were given on a seven-point scale ranging from 1 (*completely disagree*) to 7 (*completely agree*).

2.2.3 Materialism. We also adopted the Youth Materialism Scale (Goldberg *et al.*, 2003) to measure adolescent materialism in the current study. The scale also showed good reliability on a Chinese sample (Ding *et al.*, 2019a). Participants rated to what degree they agreed across ten items – for example, "I'd rather spend time buying things than doing almost anything else", "I would be happier if I had more money to buy more things for myself", "I have fun just thinking of all the things I own", "I really enjoy going shopping", "I like to buy things my friends have" and "I really like the kids that have very special games or clothes".

For all items, participants answer using a four-point scale from 1 (*disagree a lot*) to 2 (*disagree a little*) to 3 (*agree a little*) to 4 (*agree a lot*).

2.2.4 The family affluence scale. Given that adolescents were usually unaware of their family socioeconomic status, we measured the family socioeconomic status using the Family Affluence Scale (Currie *et al.*, 2008; Zou *et al.*, 2020), which is a scale that directly obtains information about participants' family possessions and life experience. In this scale, adolescents were asked four questions regarding their family economic condition – e.g. the number of family cars, vans or trucks (1 = *none*, 2 = *one*, 3 = *two or more*), whether participants have their own bedroom (1 = *no*, 2 = *yes*), family travel times over the past 12 months (1 = *none*, 2 = *one*, 3 = *two*, 4 = *more than two times*) and the number of family computer(s) (1 = *none*, 2 = *one*, 3 = *two*, 4 = *more than two*). We evaluated participants' family socioeconomic status by averaging the summed four scores, with lower scores indicating a low level of family affluence, and higher scores indicating a high level of family affluence. The range of the answers was from 1 to 3.25, the mean score was 1.93 and the standard deviation was 0.61.

2.3 Statistical procedures

We analysed the data with R 4.0.4 for Mac OS X GUI and RStudio Version 1.4.1106. To begin with, *lavaan* and *semPlot* packages were used to conduct confirmatory factor analysis (CFA). Following this, we tested the hypothetical model and competing model using the package *processR* (Moon, 2021), which was created based on PROCESS macro for SPSS and SAS (Hayes and Rockwood, 2020). In this study, we ran 95% bias-corrected accelerated confidence intervals (CIs) based on 5,000 bootstrap samples. Statistical significance is represented by a 95% CI that does not include zero. We used standardised scores to calculate the hypothetical models.

3. Results

3.1 Confirmatory factor analysis

We adopted Cronbach's α to test the reliability of the constructs. As was shown in Table 1, the value of Cronbach's α for each constructs is above 0.6, indicating either acceptable or good reliability (Taber, 2018). The composite reliability (CR) of each construct is greater than 0.70 (Table 1), showing acceptable internal consistency of items in each scale.

We used average variance extracted (AVE) to assess convergent validity. According to Fornell and Larcker (1981), 0.4 of AVE is acceptable if the CR is higher than 0.6. As was indicated in Table 2, the AVE of all constructs is either approximately 0.4 or above 0.5, indicating not good but acceptable convergent validity.

For discriminant validity, we followed Fornell and Larcker's (1981) criteria that the maximum shared variance (MSV) should be lower than AVE, and AVE should be higher than the average shared variance (ASV). As was shown in Table 3, all constructs showed good discriminant validity.

Table 1 Factor loading and Cronbach's α

Constructs	Factor loading	Cronbach's α	CR
Proenvironmental behaviour	0.53/0.73/0.77/0.63/0.58/0.43	0.74	0.79
Psychological entitlement	0.70/0.57/0.76/0.81/0.72/0.65/0.85/0.75/0.66	0.90	0.91
Materialism	0.63/0.77/0.51/0.63/0.60/0.67/0.55/0.63/0.66/0.47	0.85	0.86
Family affluence	0.79/0.38/0.57/0.66	0.66	0.70

Table 2 Construct validity (CR/AVE/MSV/ASV)

	<i>PrB</i>	<i>PsE</i>	<i>Mtr</i>	<i>FmA</i>	<i>CR</i>	<i>AVE</i>	<i>MSV</i>	<i>ASV</i>
<i>PrB</i>	1				0.79	0.38	0.07	0.04
<i>PsE</i>	-0.09	1			0.91	0.52	0.34	0.12
<i>Mtr</i>	-0.24	0.58	1		0.86	0.37	0.34	0.13
<i>FmA</i>	-0.26	-0.13	0.03	1	0.70	0.38	0.07	0.03

Table 3 Model fit analysis (CMIN/DF)

<i>Model</i>	<i>NPAR</i>	<i>CMIN</i>	<i>DF</i>	<i>p</i>	<i>CMIN/DF</i>
Default model	64	1,100.961	371	0.000	2.968

Notes: NPAR: Number of distinct parameters; DF: Degree of freedom; *p*: Significance value; CMIN/DF: Minimum discrepancy divided by degree of freedom

The results of the CFA were shown in Figure 1 and Table 2, indicating acceptable validity. Moreover, the fit indices of the measurement model are either acceptable or good, as was shown in Tables 3 and 4 (Hooper *et al.*, 2008; Arya *et al.*, 2019).

3.2 Theorised mediation model

Based on our theoretical framework, we tested the association between proenvironmental behaviour, psychological entitlement and materialism through Model 4 from *processR* package. Controlling for the correlated demographics, the results showed that proenvironmental behaviour was negatively associated with PE ($B = -0.08, p < 0.05$), psychological entitlement was positively associated with materialism ($B = 0.50, p < 0.001$) and proenvironmental behaviour was negatively associated with materialism ($B = -0.13, p < 0.001$). Psychological

Figure 1 CFA model

Table 4 Model fit analysis (CFI, GFI, NFI, TLI, RMSEA)

Model	CFI	GFI	NFI	TLI	RMSEA
Default model	0.913	0.906	0.875	0.905	0.050

Notes: CFI: Comparative fit index; GFI: Goodness of fit index; NFI: Normed fit index; TLI: Tucker–Lewis coefficient; RMSEA: Root mean square error of approximation

entitlement significantly mediated the association between proenvironmental behaviour and materialism ($ab = -0.04$, 95% CI = $[-0.02, -0.06]$, $p < 0.05$). The mediation effect accounted for 31.0% of the total effect ($b = -0.13$, 95% CI = $[-0.08, -0.21]$, $p < 0.001$). Given that the indirect and direct effects point to the same direction, the mediation type is complementary mediation. Figure 2 shows the statistical diagram.

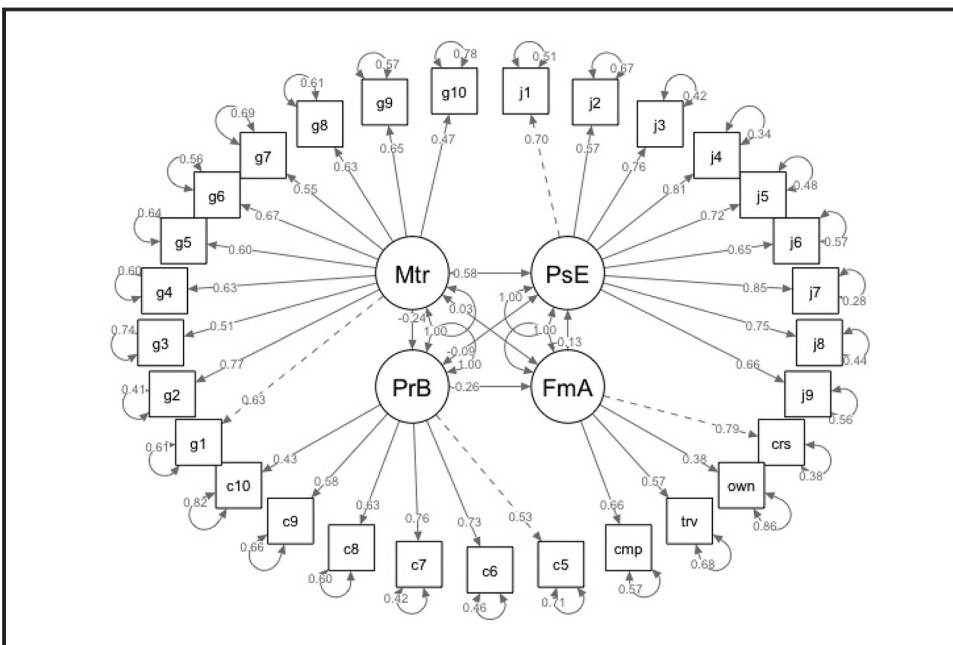
3.3 Alternative mediation models

Following the practice recommended by previous methodological literature (Lawrence *et al.*, 2006) and adopted by previous empirical research (Orkibi and Ronen, 2017), we attempted an alternative model, with the dependent and independent variables reversed, to find the appropriate directions. The results show that the path between psychological entitlement and proenvironmental behaviour was not significant in the alternative model, where materialism was the predictor and proenvironmental behaviour was the outcome variable ($B = 0.007$, $p = 0.86$, Figure 3).

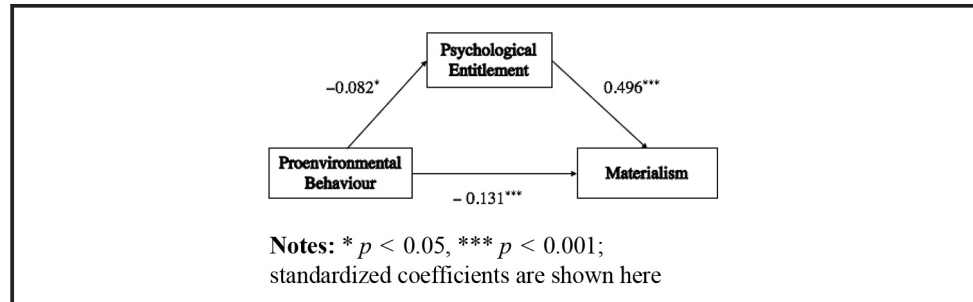
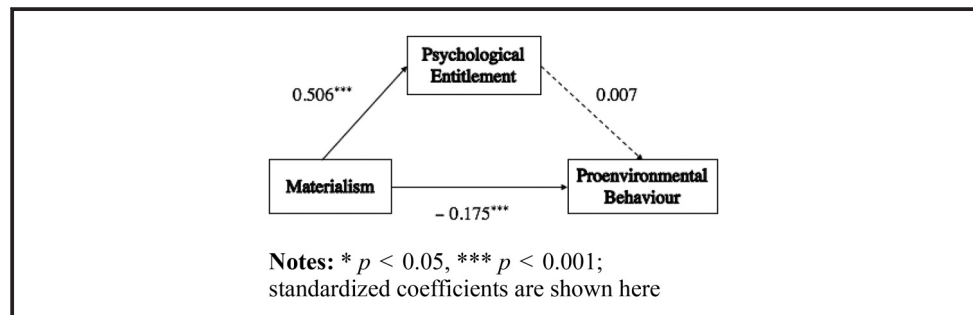
Figure 2 The theorized Model 4**Figure 3** The alternative Model 4

3.4 The moderated mediation model

We adopted Model 7 from *processR* package to test the moderated mediation model. Figure 4 displays the results. The results showed that the interaction between proenvironmental behaviour and family socioeconomic status was associated with psychological entitlement ($B = -0.09$, $p < 0.05$). The mediating role of psychological entitlement on the association between proenvironmental behaviour and materialism was significant ($ab = -0.05$, $p < 0.05$). The mediation effect accounted for 35.0% of the total effect ($b = -0.13$, $p < 0.001$).

In addition, a simple slope test (Aiken *et al.*, 1991) revealed there was no significant association between proenvironmental behaviour and psychological entitlement ($B_{\text{simple}} = 0.08$, $p = 0.92$) for adolescents with lower family socioeconomic status (-1 SD). By contrast, for adolescents with higher family socioeconomic status ($+1$ SD), higher engagement in proenvironmental behaviour significantly predicted lower psychological entitlement ($B_{\text{simple}} = -0.25$, $p < 0.001$). Figure 5 shows the interaction plot.

4. Discussion

The mediation analysis revealed that adolescent proenvironmental behaviour was negatively associated with materialism, and that psychological entitlement significantly mediated the association between adolescent proenvironmental behaviour and materialism. Based on the theory of basic individual values (Schwartz *et al.*, 2012), we explained that adolescents who engaged in proenvironmental behaviour were likely to have self-transcendental values, which decreased materialism, a self-enhancement value. In addition, according to the social learning (Bandura, 1971) and social cognitive theories (Bandura, 2018), repeated proenvironmental behaviour can provide adolescents positive experience (Tezer and Bodur, 2020), which helps them to develop self-transcendence and restrain materialism.

The moderated mediation model showed that the negative association between proenvironmental behaviour and psychological entitlement was only significant for adolescents from higher family socioeconomic status. The reason for the results could be that the effect of proenvironmental behaviour on psychological entitlement weakened because stronger factors, such as social class, affected lower class adolescents' psychological entitlement.

4.1 Theoretical implications

First, previous studies rarely explored the individual belief or perception accounting for the negative association between proenvironmental behaviour and materialism (Gu *et al.*, 2020),

Figure 4 The moderated mediation model

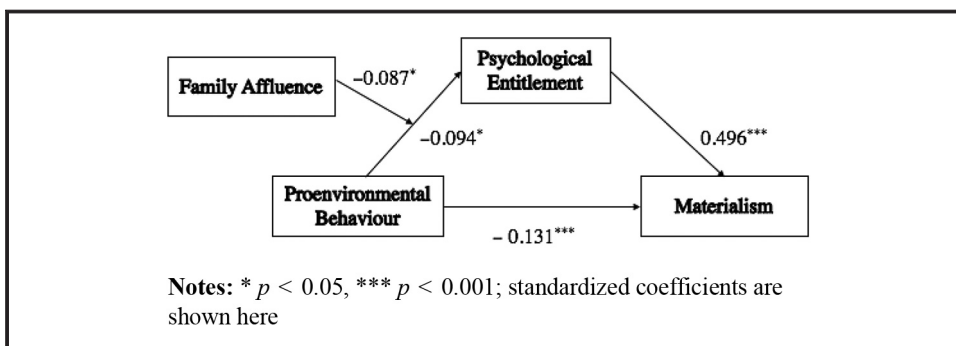
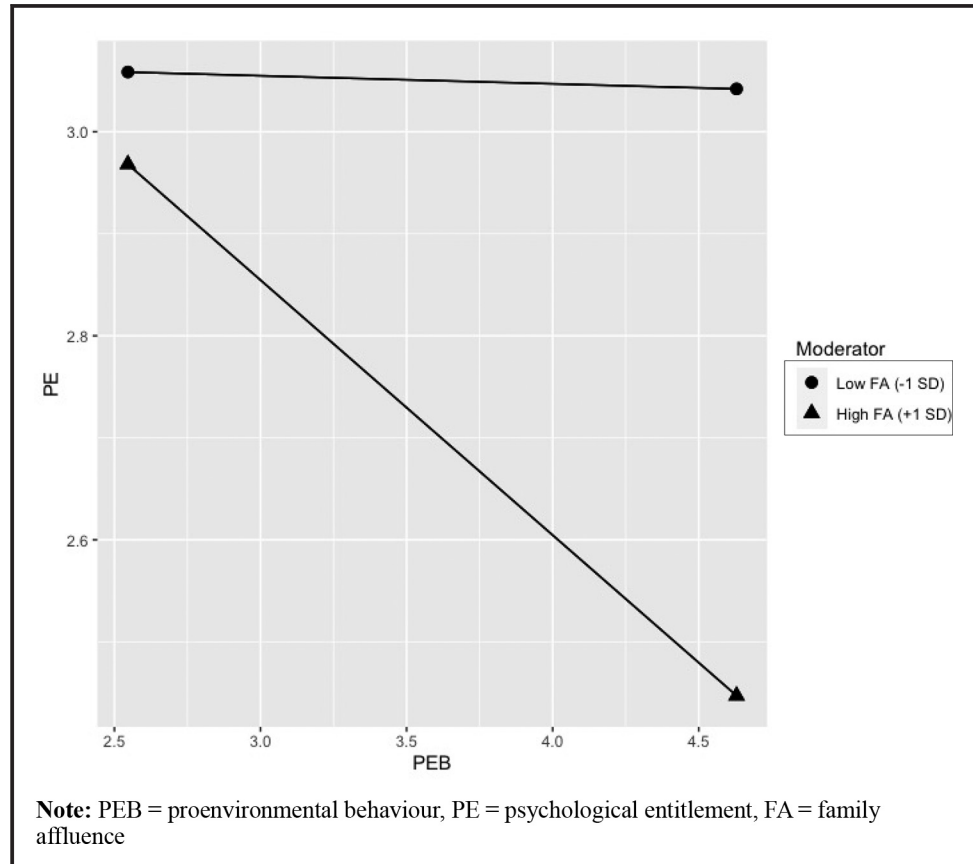

Figure 5 The interaction plot



and therefore, they were inadequate to explain why more proenvironmental behaviour could lead to less materialistic value. To fill this gap, we draw on the circular model of basic individual values (Schwartz *et al.*, 2012), social learning theory (Bandura, 1971) and the social cognitive theory (Bandura, 2018), adopting psychological entitlement, a belief reflecting the dark side of individual perception, to illustrate the negative relationship between proenvironmental behaviour and materialism.

Additionally, previous studies paid little attention to economic constraints in a family when examining antecedents of adolescent materialism (Felix and Almaguer, 2019; Zawadzka *et al.*, 2021), while materialism is a value closely related to money acquisition. Therefore, testing family socioeconomic status as a moderator to the current model helps to illustrate how economic factors influence adolescent materialism.

4.2 Practical implications

Practically, identifying the personal benefits of proenvironmental behaviour can motivate young people to act proenvironmentally by conveying that they may not always have to sacrifice self-interests (Griskevicius *et al.*, 2012), which not only factually reduces over-consumption but also attracts attention from young people towards the environment. At present, environmental education has laid too much emphasis on how much we can give rather than how much we can receive (Gleim *et al.*, 2013). Drawing from the previous (Kasser, 2017; Tezer and Bodur, 2020; Kang *et al.*, 2021) and current results, we conclude that adolescents can benefit from proenvironmental behaviour.

The current study is also significant for the environment because a reduction of adolescent materialism can decrease the increasing amount of products that young people consume (Buijzen, 2007), which factually alleviates the environmental burden. Moreover, as sustainable lifestyle is becoming a new trend that stimulates reputation and self-identification among young people (Griskevicius *et al.*, 2010; Fjeldstad, 2017; McNeill and Venter, 2019; Legere and Kang, 2020), encouraging young people into proenvironmental behaviour in the context of the trend creates a niche for environmental protection.

In addition, the current study can advise educational practitioners on alleviating adolescent materialism. Policy makers and schools can add more environmental practice to the curriculum and extracurricular activities to intervene adolescent materialism. For example, schools and organisations can encourage and organise students to collect their own products for charity, pick up trash in tourist sites, plant trees in urban areas or join a forest management game (Fritsche *et al.*, 2010). Proenvironmental behaviour as a strategy to shape adolescents' values and reduce materialism is financially viable in both economically advantaged and disadvantaged countries and areas. The specific activities can be created according to the economic and social conditions in various countries and cultures.

Lastly, the result that proenvironmental behaviour is negatively associated with psychological entitlement merely for adolescents with higher family affluence provides schools and health practitioners with practical suggestion. Psychological entitlement is a problematic belief that perplexes contemporary young people and brings about social problems to society (Grubbs and Exline, 2016). However, interventions to perception and belief have been challenging to practice. The current study suggests that encouraging adolescents from affluent family to engage in proenvironmental behaviour may help to decrease their psychological entitlement. This suggestion is particularly actionable because higher classed people are more likely than their lower classed counterparts to receive better environmental education, accept proenvironmental value and have more proenvironmental behaviour (Yan *et al.*, 2021).

4.3 Future directions

The current study provides insights into the study of eco-friendly luxury fashion trends in the context of the green campaign of luxury brands. From a traditional view, luxury brands encapsulate and advocate a materialistic lifestyle and are one of the culprits for materialism in the consumerist society. Eco-friendly luxury fashion seems to be a contradictory notion and luxury brands that promote green values have been suspicious of "greenwashing" (Du, 2015). However, luxury and fashion trends are socially constructed so that the definition and connotation of luxury are developing across time (Hemetsberger *et al.*, 2012). In the past centuries, owning more means more freedom (Veblen, 1912), whereas owning less releases modern consumers from emotional impediment (Kang *et al.*, 2021).

On the one hand, as the functions of luxury are changing from status manifestation to self-representation (Carrigan *et al.*, 2013), consumers become increasingly interested in what values the brands hold and promote. On the other hand, the fashion industry has become ever more concerned with consumers' demand for more sustainable consumption and has created new concepts, such as "buy less, buy better" and "slow fashion", in contrast with the "fast fashion" promoted by high-street retailers (Sun *et al.*, 2021). Therefore, luxury brands that are eco-friendly may no longer be a symbol of materialism and may appeal to consumers who are concerned with social topics.

Nevertheless, buying and owning any commercial products involve the possession and consumption of materials and resources. Research has found that even just living in wealthy neighbourhoods generates cravings for material consumption (Zhang *et al.*, 2016), indicating that materialist or consumerist reminders exist in the social surroundings; for example, the prevailing commercial campaign of luxury products can easily trigger material desires.

Therefore, although some luxury purchases are manufactured and sold as eco-friendly, owning too much of them could still become psychologically entitled and materialistic.

In addition, research has revealed that consumers tend to adopt green consumption as a strategy to exhibit high status and good reputation (Griskevicius *et al.*, 2010). This study suggests that luxury brands can provide consumers with a sense of luxury through promoting green lifestyle. In conclusion, future studies can illustrate whether psychological entitlement and materialism are associated with green luxury consumption.

5. Limitations

Although the current study provides implications, two limitations must be raised. Firstly, it is of remote likelihood to draw causal conclusions with regard to the cross-sectional nature of the current design. To remedy this limitation, we have run a competing model in the statistical analysis and found that the model with reversed dependent and independent variables is not significant. Still, a cross-lagged analysis on a longitudinal data would be more reliable to draw certain conclusions.

Secondly, as all the participants are from mainland China, the results could be different on samples from other cultural contexts. Given that the association between proenvironmental behaviour and materialism is not consistently negative (Evers *et al.*, 2018), we suggest that results may vary regarding different culture backgrounds. Specifically, the items of proenvironmental behaviour may reflect green lifestyle and green commitment in the western culture, whereas some items could merely show adolescents' frugal values that comply to the traditional Chinese admonition (Cheung *et al.*, 2003) – e.g. "I turn off TV and computer screens when they are not in use" and "I conserve energy and water by taking shorter showers". In that case, the negative association between proenvironmental behaviour and materialism may be better explained by the attitude towards saving money.

References

- Aiken, L.S., West, S.G. and Reno, R.R. (1991), *Multiple Regression: Testing and Interpreting Interactions*, Sage, New York, NY.
- Alzubaidi, H., Slade, E.L. and Dwivedi, Y.K. (2021), "Examining antecedents of consumers' pro-environmental behaviours: TPB extended with materialism and innovativeness", *Journal of Business Research*, Vol. 122, pp. 685-699.
- Arya, V., Sethi, D. and Paul, J. (2019), "Does digital footprint act as a digital asset? – enhancing brand experience through remarketing", *International Journal of Information Management*, Vol. 49, pp. 142-156.
- Bandura, A. (1971), *Social Learning Theory*, General Learning Press, New York, NY.
- Bandura, A. (2014), "Social cognitive theory of moral thought and action", in William, M.K., Gewirtz, J. and Lamb, J.L. (Eds), *Handbook of Moral Behavior and Development*, Psychology Press, New York, NY, pp. 69-128.
- Bandura, A. (2018), "Toward a psychology of human agency: pathways and reflections", *Perspectives on Psychological Science*, Vol. 13 No. 2, pp. 130-136.
- Barton, A.L. and Hirsch, J.K. (2016), "Permissive parenting and mental health in college students: mediating effects of academic entitlement", *Journal of American College Health*, Vol. 64 No. 1, pp. 1-8.
- Belk, R.W. (1985), "Materialism: Trait aspects of living in the material world", *Journal of Consumer Research*, Vol. 12 No. 3, pp. 265-280.
- Bergman, J.Z., Westerman, J.W., Bergman, S.M., Westerman, J. and Daly, J.P. (2014), "Narcissism, materialism, and environmental ethics in business students", *Journal of Management Education*, Vol. 38 No. 4, pp. 489-510.
- Bishop, J. and Lane, R.C. (2000), "Father absence and the attitude of entitlement", *Journal of Contemporary Psychotherapy*, Vol. 30 No. 1, pp. 105-117.

- Boyd, III H.C. and Helms, J.E. (2005), "Consumer entitlement theory and measurement", *Psychology and Marketing*, Vol. 22 No. 3, pp. 271-286.
- Briggs, E., Landry, T. and Wood, C. (2007), "Beyond just being there: an examination of the impact of attitudes, materialism, and self-esteem on the quality of helping behavior in youth volunteers", *Journal of Nonprofit & Public Sector Marketing*, Vol. 18 No. 2, pp. 27-45.
- Brown, K.W. and Kasser, T. (2005), "Are psychological and ecological well-being compatible? The role of values, mindfulness, and lifestyle", *Social Indicators Research*, Vol. 74 No. 2, pp. 349-368.
- Brown, K.W., Kasser, T., Ryan, R.M., Alex Linley, P. and Orzech, K. (2009), "When what one has is enough: mindfulness, financial desire discrepancy, and subjective well-being", *Journal of Research in Personality*, Vol. 43 No. 5, pp. 727-736.
- Buijzen, M. (2007), "Reducing children's susceptibility to commercials: mechanisms of factual and evaluative advertising interventions", *Media Psychology*, Vol. 9 No. 2, pp. 411-430.
- Burroughs, J.E. and Rindfleisch, A. (2002), "Materialism and well-being: a conflicting values perspective", *Journal of Consumer Research*, Vol. 29 No. 3, pp. 348-370.
- Campbell, W.K., Bonacci, A.M., Shelton, J., Exline, J.J. and Bushman, B.J. (2004), "Psychological entitlement: interpersonal consequences and validation of a self-report measure", *Journal of Personality Assessment*, Vol. 83 No. 1, pp. 29-45.
- Carrigan, M., Moraes, C. and McEachern, M. (2013), "From conspicuous to considered fashion: a harm-chain approach to the responsibilities of luxury-fashion businesses", *Journal of Marketing Management*, Vol. 29 Nos 11/12, pp. 1277-1307.
- Chan, K. and Prendergast, G. (2007), "Materialism and social comparison among adolescents", *Social Behavior and Personality: An International Journal*, Vol. 35 No. 2, pp. 213-228.
- Chan, K. and Prendergast, G.P. (2008), "Social comparison, imitation of celebrity models and materialism among Chinese youth", *International Journal of Advertising*, Vol. 27 No. 5, pp. 799-826.
- Chan, K., Zhang, H. and Wang, I. (2006), "Materialism among adolescents in urban China", *Young Consumers*, Vol. 7 No. 2, pp. 64-77.
- Chaplin, L.N. and John, D.R. (2007), "Growing up in a material world: age differences in materialism in children and adolescents", *Journal of Consumer Research*, Vol. 34 No. 4, pp. 480-493.
- Cheung, F.M., Kwong, J.Y. and Zhang, J. (2003), "Clinical validation of the Chinese personality assessment inventory", *Psychological Assessment*, Vol. 15 No. 1, pp. 89-100.
- Clark, M.S., Greenberg, A., Hill, E., Lemay, E.P., Clark-Polner, E. and Roosth, D. (2011), "Heightened interpersonal security diminishes the monetary value of possessions", *Journal of Experimental Social Psychology*, Vol. 47 No. 2, pp. 359-364.
- Currie, C., Molcho, M., Boyce, W., Holstein, B., Torsheim, T. and Richter, M. (2008), "Researching health inequalities in adolescents: the development of the health behaviour in School-Aged children (HBSC) family affluence scale", *Social Science & Medicine*, Vol. 66 No. 6, pp. 1429-1436.
- De Rezende Pinto, M., Mota, A.O., Leite, R.S. and Alves, R.C. (2017), "Investigating the influencers of materialism in adolescence", *Tourism & Management Studies*, Vol. 13 No. 1, pp. 66-74.
- Ding, Q., Kong, L.L., Zhang, Y.X. and Zhou, Z.K. (2019a), "Parental materialism and college students' online compulsive buying: a serial mediating effect analysis", *Psychological Development and Education*, Vol. 35 No. 5, pp. 549-556.
- Ding, Q., Liang, Y.B., Zhang, Y.X. and Huang, F. (2019b), "The impact of attribution for the rich-poor gap on psychological entitlement among low social class college students: the mediating effect of relative deprivation", *Chinese Journal of Clinical Psychology*, Vol. 27 No. 5, pp. 1041-1044.
- Dittmar, H., Bond, R., Hurst, M. and Kasser, T. (2014), "The relationship between materialism and personal well-being: a meta-analysis", *Journal of Personality and Social Psychology*, Vol. 107 No. 5, pp. 879-924.
- Du, X. (2015), "How the market values greenwashing? Evidence from China", *Journal of Business Ethics*, Vol. 128 No. 3, pp. 547-574.
- Durvasula, S. and Lysonski, S. (2010), "Money, money, money – how do attitudes toward money impact vanity and materialism? – the case of young Chinese consumers", *Journal of Consumer Marketing*, Vol. 27 No. 2, pp. 169-179.

- Eisenberg, N., Guthrie, I.K., Cumberland, A., Murphy, B.C., Shepard, S.A., Zhou, Q. and Carlo, G. (2002), "Prosocial development in early adulthood: a longitudinal study", *Journal of Personality and Social Psychology*, Vol. 82 No. 6, pp. 993-1006.
- Etikan, I., Musa, S.A. and Alkassim, R.S. (2016), "Comparison of convenience sampling and purposive sampling", *American Journal of Theoretical and Applied Statistics*, Vol. 5 No. 1, pp. 1-4.
- Evers, U., Gruner, R.L., Sneddon, J. and Lee, J.A. (2018), "Exploring materialism and frugality in determining product end-use consumption behaviors", *Psychology & Marketing*, Vol. 35 No. 12, pp. 948-956.
- Felix, R. and Almaguer, J. (2019), "Nourish what you own: psychological ownership, materialism and pro-environmental behavioral intentions", *Journal of Consumer Marketing*, Vol. 36 No. 1, pp. 82-91.
- Fjeldstad, V. (2017), "Scaffolding second-hand fashion consumption among adolescent girls-Cool and sustainable app design for better user experience of redistribution of clothing", master's thesis, NORA – Norwegian Open Research Archives.
- Flanagan, C.A., Gallay, L.S., Gill, S., Gallay, E. and Nti, N. (2005), "What does democracy mean? Correlates of adolescents' views", *Journal of Adolescent Research*, Vol. 20 No. 2, pp. 193-218.
- Fornell, C. and Larcker, D.F. (1981), "Evaluating structural equation models with unobservable variables and measurement error", *Journal of Marketing Research*, Vol. 18 No. 1, pp. 39-50.
- Fritsche, I., Jonas, E., Kayser, D.N. and Koranyi, N. (2010), "Existential threat and compliance with pro-environmental norms", *Journal of Environmental Psychology*, Vol. 30 No. 1, pp. 67-79.
- Gleim, M.R., Smith, J.S., Andrews, D. and Cronin, J.J. (2013), "Against the green: a multi-method examination of the barriers to green consumption", *Journal of Retailing*, Vol. 89 No. 1, pp. 44-61.
- Goldberg, M.E., Gorn, G.J., Peracchio, L.A. and Bamossy, G. (2003), "Understanding materialism among youth", *Journal of Consumer Psychology*, Vol. 13 No. 3, pp. 278-288.
- Goldstein, N.J., Cialdini, R.B. and Griskevicius, V. (2008), "A room with a viewpoint: using social norms to motivate environmental conservation in hotels", *Journal of Consumer Research*, Vol. 35 No. 3, pp. 472-482.
- Griskevicius, V., Cantú, S.M. and Van Vugt, M. (2012), "The evolutionary bases for sustainable behavior: implications for marketing, policy, and social entrepreneurship", *Journal of Public Policy & Marketing*, Vol. 31 No. 1, pp. 115-128.
- Griskevicius, V., Tybur, J.M. and Van den Bergh, B. (2010), "Going green to be seen: status, reputation, and conspicuous conservation", *Journal of Personality and Social Psychology*, Vol. 98 No. 3, pp. 392-404.
- Grubbs, J.B. and Exline, J.J. (2016), "Trait entitlement: a cognitive-personality source of vulnerability to psychological distress", *Psychological Bulletin*, Vol. 142 No. 11, pp. 1204-1226.
- Gu, F.F. and Hung, K. (2009), "Materialism among adolescents in China: a historical generation perspective", *Journal of Asia Business Studies*, Vol. 3 No. 2, pp. 56-64.
- Gu, D., Gao, S., Wang, R., Jiang, J. and Xu, Y. (2020), "The negative associations between materialism and pro-environmental attitudes and behaviors: individual and regional evidence from China", *Environment and Behavior*, Vol. 52 No. 6, pp. 611-638.
- Gupta, A., Jain, V.K., Arya, V. and Verma, H. (2022), "Consumer green consumption behavior: a myth or reality in the information age? A study based on bibliometric analysis approach", *Information Resources Management Journal (IRMJ)*, Vol. 35 No. 2, pp. 1-19.
- Hart, W., Tortoriello, G.K. and Richardson, K. (2019), "Deprived and grandiose explanations for psychological entitlement: implications for theory and measurement", *Journal of Personality Assessment*, Vol. 102 No. 4, pp. 488-498.
- Hayes, A.F. and Rockwood, N.J. (2020), "Conditional process analysis: concepts, computation, and advances in the modeling of the contingencies of mechanisms", *American Behavioral Scientist*, Vol. 64 No. 1, pp. 19-54.
- Helm, S., Serido, J., Ahn, S., Ligon, V. and Shim, S. (2019), "Materialist values, financial and pro-environmental behaviors, and well-being", *Young Consumers*, Vol. 20 No. 4, pp. 264-284.
- Hemetsberger, A., von Wallpach, S. and Bauer, M. (2012), "Because I'm worth it-luxury and the construction of consumers' selves", *Advances in Consumer Research*, Vol. 40, pp. 484-489.
- Henderson-King, D. and Brooks, K.D. (2009), "Materialism, sociocultural appearance messages, and paternal attitudes predict college women's attitudes about cosmetic surgery", *Psychology of Women Quarterly*, Vol. 33 No. 1, pp. 133-142.

- Hooper, D., Coughlan, J. and Mullen, M.R. (2008), "Structural equation modelling: guidelines for determining model fit", *The Electronic Journal of Business Research Methods*, Vol. 6, pp. 53-60.
- Hurst, M., Dittmar, H., Bond, R. and Kasser, T. (2013), "The relationship between materialistic values and environmental attitudes and behaviors: a Meta-analysis", *Journal of Environmental Psychology*, Vol. 36, pp. 257-269.
- Kamal, S., Chu, S.C. and Pedram, M. (2013), "Materialism, attitudes, and social media usage and their impact on purchase intention of luxury fashion goods among American and Arab young generations", *Journal of Interactive Advertising*, Vol. 13 No. 1, pp. 27-40.
- Kang, J., Martinez, C.M.J. and Johnson, C. (2021), "Minimalism as a sustainable lifestyle: its behavioral representations and contributions to emotional well-being", *Sustainable Production and Consumption*, Vol. 27, pp. 802-813.
- Kasser, T. (2016), "Materialistic values and goals", *Annual Review of Psychology*, Vol. 67 No. 1, pp. 489-514.
- Kasser, T. (2017), "Living both well and sustainably: a review of the literature, with some reflections on future research, interventions and policy", *Philosophical Transactions of the Royal Society A: Mathematical, Physical and Engineering Sciences*, Vol. 375 No. 2095, pp. 1-13.
- Kasser, T. and Ryan, R.M. (1993), "A dark side of the American dream: correlates of financial success as a Central life aspiration", *Journal of Personality and Social Psychology*, Vol. 65 No. 2, pp. 410-422.
- Kilbourne, W. and Pickett, G. (2008), "How materialism affects environmental beliefs, concern, and environmentally responsible behavior", *Journal of Business Research*, Vol. 61 No. 9, pp. 885-893.
- Kim, D.S. and Kim, H.S. (2009), "Body - image dissatisfaction as a predictor of suicidal ideation among Korean boys and girls in different stages of adolescence: a two-year longitudinal study", *Journal of Adolescent Health*, Vol. 45 No. 1, pp. 47-54.
- Kraus, M.W., Piff, P.K., Mendoza-Denton, R., Rheinschmidt, M.L. and Keltner, D. (2012), "Social class, solipsism, and contextualism: how the rich are different from the poor", *Psychological Review*, Vol. 119 No. 3, pp. 546-572.
- Krettenauer, T. (2017), "Pro-environmental behavior and adolescent moral development", *Journal of Research on Adolescence*, Vol. 27 No. 3, pp. 581-593.
- Ku, L. (2015), "Development of materialism in adolescence: the longitudinal role of life satisfaction among Chinese youths", *Social Indicators Research*, Vol. 124 No. 1, pp. 231-247.
- Lasaleta, J.D., Sedikides, C. and Vohs, K.D. (2014), "Nostalgia weakens the desire for money", *The Journal of Consumer Research*, Vol. 41 No. 3, pp. 713-729.
- Lawrence, R.J., Stanley, A.M. and Brett, J.M. (2006), "A tale of two methods", *Organizational Research Methods*, Vol. 9 No. 2, pp. 233-244.
- Lee, C.S., Chugani, S. and Namkoong, J.E. (2022), "The role of entitlement and perceived resources in gratitude's effect on materialism: longitudinal and situational effects", *Journal of Business Research*, Vol. 139, pp. 993-1003.
- Legere, A. and Kang, J. (2020), "The role of self-concept in shaping sustainable consumption: a model of slow fashion", *Journal of Cleaner Production*, Vol. 258, pp. 1-12.
- Lewallen, J., Miller, B. and Behm-Morawitz, E. (2016), "Lifestyles of the rich and famous: celebrity media diet and the cultivation of emerging adults' materialism", *Mass Communication and Society*, Vol. 19 No. 3, pp. 253-274.
- McHoskey, J.W. (1999), "Machiavellianism, intrinsic versus extrinsic goals, and social interest: a self-determination theory analysis", *Motivation and Emotion*, Vol. 23 No. 4, pp. 267-283.
- McNeill, L. and Venter, B. (2019), "Identity, self-concept and young women's engagement with collaborative, sustainable fashion consumption models", *International Journal of Consumer Studies*, Vol. 43 No. 4, pp. 368-378.
- Maio, G.R., Pakizeh, A., Cheung, W.Y. and Rees, K.J. (2009), "Changing, priming, and acting on values: effects via motivational relations in a circular model", *Journal of Personality and Social Psychology*, Vol. 97 No. 4, pp. 699-715.

- Moon, K.W. (2021), "R package process R", available at: <https://cran.r-project.org/web/packages/processR/vignettes/processR.html> (accessed 6 January 2021).
- Norris, J.I., Lambert, N.M., DeWall, C.N. and Fincham, F.D. (2012), "Can't buy me love?: anxious attachment and materialistic values", *Personality and Individual Differences*, Vol. 53 No. 5, pp. 666-669.
- Oprea, S.J. and Kühne, R. (2016), "Generation me in the spotlight: linking reality TV to materialism, entitlement, and narcissism", *Mass Communication and Society*, Vol. 19 No. 6, pp. 800-819.
- Orkibi, H. and Ronen, T. (2017), "Basic psychological needs satisfaction mediates the association between self-control skills and subjective well-being", *Frontiers in Psychology*, Vol. 8, pp. 936-936.
- Peterson, R.A. and Merunka, D.R. (2014), "Convenience samples of college students and research reproducibility", *Journal of Business Research*, Vol. 67 No. 5, pp. 1035-1041.
- Pieters, R. (2013), "Bidirectional dynamics of materialism and loneliness: not just a vicious cycle", *Journal of Consumer Research*, Vol. 40 No. 4, pp. 615-631.
- Podoshen, J.S., Li, L. and Zhang, J. (2011), "Materialism and conspicuous consumption in China: a cross-cultural examination", *International Journal of Consumer Studies*, Vol. 35 No. 1, pp. 17-25.
- Richins, M.L. and Chaplin, L.N. (2015), "Material parenting: how the use of goods in parenting fosters materialism in the next generation", *Journal of Consumer Research*, Vol. 41 No. 6, pp. 1333-1357.
- Richins, M.L. and Dawson, S. (1992), "A consumer values orientation for materialism and its measurement: scale development and validation", *Journal of Consumer Research*, Vol. 19 No. 3, pp. 303-316.
- Schwartz, S.H., Cieciuch, J., Vecchione, M., Davidov, E., Fischer, R., Beierlein, C., ... and Konty, M. (2012), "Refining the theory of basic individual values", *Journal of Personality and Social Psychology*, Vol. 103 No. 4, pp. 663-688.
- Shrum, L.J., Wong, N., Arif, F., Chugani, S.K., Gunz, A., Lowrey, T.M., ... and Sundie, J. (2013), "Reconceptualizing materialism as identity goal pursuits: functions, processes, and consequences", *Journal of Business Research*, Vol. 66 No. 8, pp. 1179-1185.
- Solomon, M.R. (1983), "The role of products as social stimuli: a symbolic interactionism perspective", *Journal of Consumer Research*, Vol. 10 No. 3, pp. 319-329.
- Sreen, N., Purbey, S. and Sadarangani, P. (2020), "Understanding the relationship between different facets of materialism and attitude toward green products", *Journal of Global Marketing*, Vol. 33 No. 5, pp. 396-416.
- Stillman, T.F., Fincham, F.D., Vohs, K.D., Lambert, N.M. and Phillips, C.A. (2012), "The material and immaterial in conflict: spirituality reduces conspicuous consumption", *Journal of Economic Psychology*, Vol. 33 No. 1, pp. 1-7.
- Sun, J.J., Bellezza, S. and Paharia, N. (2021), "Buy less, buy luxury: understanding and overcoming product durability neglect for sustainable consumption", *Journal of Marketing*, Vol. 85 No. 3, pp. 28-43.
- Taber, K.S. (2018), "The use of Cronbach's alpha when developing and reporting research instruments in science education", *Research in Science Education*, Vol. 48 No. 6, pp. 1273-1296.
- Tezer, A. and Bodur, H.O. (2020), "The green consumption effect: how using green products improves consumption experience", *Journal of Consumer Research*, Vol. 47 No. 1, pp. 25-39.
- Twenge, J.M. and Foster, J.D. (2010), "Birth cohort increases in narcissistic personality traits among American college students, 1982-2009", *Social Psychological and Personality Science*, Vol. 1 No. 1, pp. 99-106.
- Veblen, T. (1912), *The Theory of the Leisure Class*, 2nd ed., Macmillan, New York, NY.
- Wang, C.Y., Yu, Q.T., Wang, C.Z. and Liu, Z.L. (2019), "The influence of natural connection on teenagers' pro-environmental tendency", *Journal of Xinyang Normal University*, Vol. 39 No. 6, pp. 59-64.
- Yan, L., Keh, H.T. and Chen, J. (2021), "Assimilating and differentiating: the curvilinear effect of social class on green consumption", *Journal of Consumer Research*, Vol. 47 No. 6, pp. 914-936.

York, J.G., Vedula, S. and Lenox, M.J. (2018), "It's not easy building green: the impact of public policy, private actors, and regional logics on voluntary standards adoption", *Academy of Management Journal*, Vol. 61 No. 4, pp. 1492-1523.

Zawadzka, A.M., Kasser, T., Niesiobędzka, M., Lewandowska-Walter, A. and Górnik-Durose, M. (2021), "Environmental correlates of adolescent materialism: interpersonal role models, media exposure, and family socio-economic status", *Journal of Child and Family Studies*, Vol. 31 No. 5, pp. 1427-1440.

Zhang, J.W., Howell, R.T. and Howell, C.J. (2016), "Living in wealthy neighborhoods increases material desires and maladaptive consumption", *Journal of Consumer Culture*, Vol. 16 No. 1, pp. 297-316.

Zou, R., Xu, X., Hong, X. and Yuan, J. (2020), "Higher socioeconomic status predicts less risk of depression in adolescence: serial mediating roles of social support and optimism", *Frontiers in Psychology*, Vol. 11, p. 1955.

Further reading

Hair, Jr J.F., Sarstedt, M., Ringle, C.M. and Gudergan, S.P. (2017), *Advanced Issues in Partial Least Squares Structural Equation Modeling*, Sage Publications, CA.

Corresponding author

Meiting Liu can be contacted at: meiliu@utu.fi

For instructions on how to order reprints of this article, please visit our website:

www.emeraldgroupublishing.com/licensing/reprints.htm

Or contact us for further details: permissions@emeraldinsight.com